

# HYUNDAI

## OIL-LESS AIR COMPRESSOR

Models HY0808/HY0816

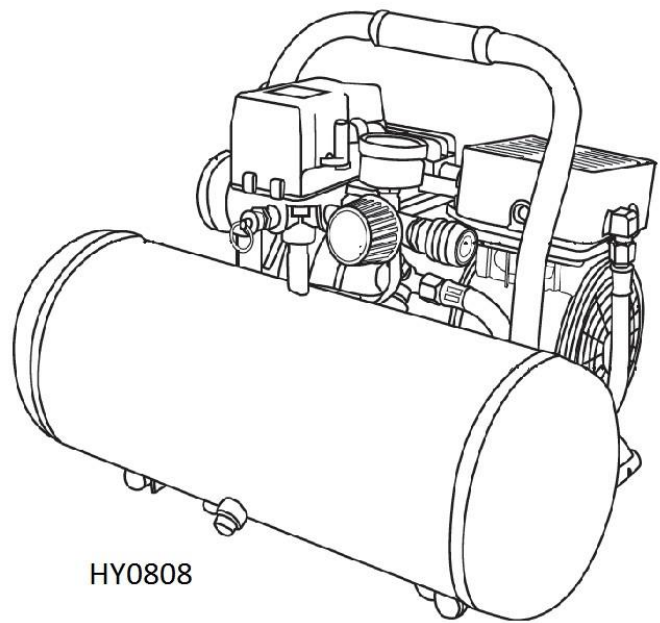
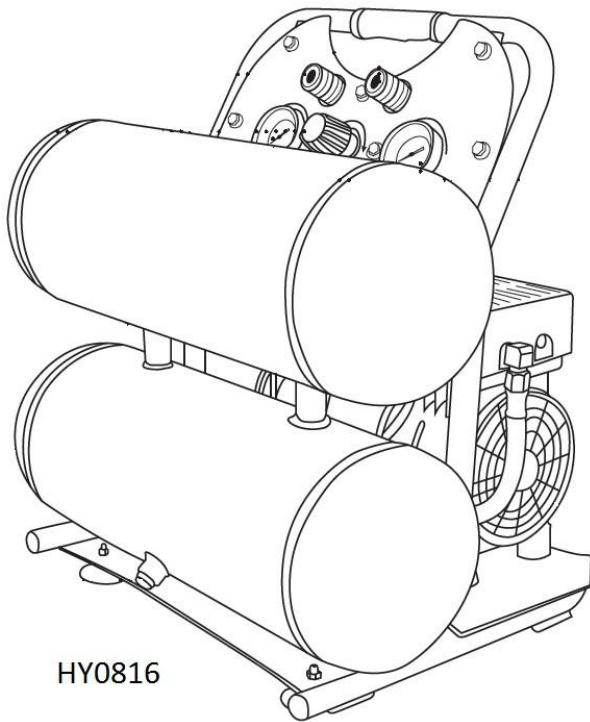

## User Guide

Licensed by Hyundai Corporation, Korea

## CONTENTS

<b>Section Description</b>	<b>Page N°/N°s</b>
RECORD OF IDENTIFICATION NUMBERS	3
1. SAFETY	4 - 8
2. BOX CONTENTS – ASSEMBLY - PARTS	9
3. INSTALLATION & EARTHING	10
4. MAINTENANCE	11 – 12
5. STORAGE	12
6. TROUBLESHOOTING	12 – 13
7. SPECIFICATIONS	13
8. ENVIRONMENTAL	14
9. GENPOWER CONTACT DETAILS	14
10. DECLARATIONS of CONFORMITY	15

## Record of Identification Numbers

If you need to contact Service department for information and servicing call on 01646 687880 (Service Option 2). Please have ready the Product Model and serial numbers.

Please make a note of the following details;

Date of Purchase	
Dealers Name	
Dealers Phone number	

Model Number	
Serial Number	

Every effort is made to continually improve our products therefore data and figures may change without notice.

1. SAFETY.  

1.1. The operator of the machine;

1.1.1. Is responsible for and has a duty of care in making sure that the compressor is operated safely and in accordance with the instructions in this user manual.

1.1.2. Should never leave it in a condition which would allow an untrained or unauthorised person/s to operate this compressor.

1.1.2.1. Should take care and show due diligence for the safety of and with regard to those around whilst using the machine, to include but not limited to;



















1.1.2.1.1. Elderly, children, pets, livestock and property.

1.2. Some or all of the following PPE, Warning Signs and symbols may appear throughout this manual and you must adhere to their warning/s. Failure to do so may result in personal injury.

Personal Protective clothing (PPE)



Warning Signs and Symbols – FOLLOW safety messages to avoid or reduce risk of injury or death.

 <b>DANGER</b> DANGER - indicates a hazard which, if not avoided, could result in serious injury or death.		 <b>WARNING</b> WARNING - indicates a hazard which, if not avoided, could result in serious injury or death.		 <b>CAUTION</b> CAUTION - indicates a hazard which, if not avoided, might result in minor or moderate injury.		 <b>NOTE</b> NOTE - indicates a situation that could easily result in equipment damage.		 READ MANUAL			
 EXPLOSION		 FIRE		 ELECTRIC SHOCK		 TOXIC FUMES		 KICKBACK		 FLUID INJECTION	
 HOT SURFACE		 FLYING OBJECTS		 SLIPPERY		 FALL		 MOVING PARTS		 HOSES UNDER PRESSURE	
 GOGGLES											



### 1.3. Electrical Safety.

- 1.3.1. Do not touch the mains plug with wet hands! Always disconnect the mains plug by pulling the plug and not the cable.
- 1.3.2. The compressor must be connected to earthed sockets which have been properly installed, earthed and tested. Mains voltage and fuse must comply with the technical data.
- 1.3.3. Do not kink, crush, drag or drive over the mains cable; protect against sharp edges, oil and heat.
- 1.3.4. Extension leads/cables must not be used.
- 1.3.5. Disconnect the mains plug before all work on the appliance.
- 1.3.6. Children and young people under the age of 16 years must not use this appliance, and must be kept away from it when it is in operation.
- 1.3.7. Repairs must be carried out only by a qualified electrician.
- 1.3.8. If repairs are carried out incorrectly, there is a danger of liquid penetrating into the electrical components of the appliance.
- 1.3.9. Clean up all spills promptly using correct methods i.e. absorbent granules and a lidded bin.



### 1.4. General Safety Information.

- 1.4.1. DO NOT operate the unit if it has been damaged either in transit or use.
- 1.4.2. The Air Compressor and other components (filters, lubrication oils/greases, hoses etc). The following safety precautions must be observed at all times.
  - 1.4.2.1. Read all manuals included with this product. Be thoroughly familiar with the controls and proper use of equipment.
  - 1.4.2.2. Follow all electrical safety regulations – if in doubt contact a qualified Electrician.
  - 1.4.2.3. Only persons well acquainted with these rules of safe operation should be allowed to use the compressor and attachments.
  - 1.4.2.4. Keep visitors away and never allow children in the work area.
  - 1.4.2.5. Always wear safety glasses and hearing protection when operating the pump or unit.
  - 1.4.2.6. Do not stand on or use the pump or unit as a handhold.
  - 1.4.2.7. Before each use, inspect the compressed air and electrical components for signs of wear, damage, deterioration, weakness or air leakages. Always repair or replace faulty items before use.
  - 1.4.2.8. Check all fasteners at frequent intervals for proper tightness.
  - 1.4.2.9. Keep fingers away from a running compressor, fast moving and hot parts will cause injury and/or burns.
  - 1.4.2.10. If the equipment start abnormally, vibrate, STOP the motor and check immediately for the cause. Vibration is a good warning of trouble with machine.
  - 1.4.2.11. To reduce fire hazards, keep motor exterior free from oil, solvents or excessive grease. Never remove or attempt to adjust safety valve. Keep safety valve free from paint and other dust and dirt.



### 1.5. Air Tank warning.

 <b>WARNING</b>  EXPLOSION	Drain liquid from air tank daily, or after each use, using the drain valve located on the bottom of the lower air tank. Failure to properly drain liquid from the tank will cause rust from the moisture build-up, which weakens the tank and could lead to a violent tank explosion. Periodically inspect tanks for unsafe conditions such as corrosion.
Never attempt to repair or make modifications to the tank or its attachments. Welding, drilling or any other modifications may weaken the tank, which may result in damage from rupture or explosion. Never remove or attempt to adjust pressure switch, safety valve or other factory set operating pressures.	



### 1.6. Fire warning.

 <b>WARNING</b>  FIRE	Avoid dangerous environments. Do not use compressor near petrol or other flammable materials. Keep work area well lit. Normal sparking of a motor or sparks from grinding metal could ignite fumes. Do not spray flammable materials in the vicinity of an open flame or other ignition source, including the air compressor itself. Do not direct paint or other spray material towards compressor.
Read and follow all safety instructions for the material you are spraying. Be sure to use an approved respirator designed for use with your specific application.	



### 1.7. Breathable air warning.

 <b>WARNING</b>  TOXIC FUMES	This compressor is not designed, nor intended for the supply of breathable quality air. Air produced by this unit may contain carbon monoxide or other toxic vapours. Carbon monoxide is colourless and odourless, inhaling this gas can cause death as well as serious long term health problems such as brain damage.
Do not inhale air from the compressor or from a breathing device connected to it.	



### 1.8. Electric shock warning.

 <b>WARNING</b>  ELECTRIC SHOCK	When using electric powered tools, machines or equipment, basic safety precautions should always be followed to minimise the risk of electric shock or personal injury to yourself and others. We recommend the use to Residual Current Device to protect the user/s against electric shock.
This air compressor is powered by electricity and should never be used without proper earth connections. Do not use in the wet or damp locations or expose unit to rain.	



### 1.9. Air tools and Accessories.

 <b>WARNING</b>  EXPLOSION	Do not exceed the pressure rating of any air tools, spray guns, accessories, or inflatables including tyres etc. Excess pressure can cause them to explode, resulting in serious injury. Follow the manufacturers recommended pressure settings for all air tools, air accessories and inflatables including tyres etc.
--	---



### 1.10. People and Pets.

 <b>WARNING</b>  GOGGLES	Do not direct compressed air stream at people or pets. The powerful compressed air stream can damaged exposed skin and propel loose dirt and other small objects. Always wear approved eye protection.
--	--



### 1.11. Hot surfaces.

 <b>WARNING</b>  HOT SURFACE	Keep hand and fingers away from exposed metal parts on a running air compressor. Air compressors generate significant heat during normal operation, which can cause serious burns. The compressor will remain hot for some time after operation and should not be touched or moved until cool. Do not cover unit with any combustible materials whilst in use or when still hot after use.
---	--

### 1.12. Moving parts.

 <b>WARNING</b>  MOVING PARTS	Keep hand and fingers away from moving parts, serious injury can occur if fingers are entangled in moving parts.
---	--

### 1.13. Spraying precautions.

 <b>WARNING</b>  FIRE	Do not spray flammable materials in the vicinity of an open flame or near ignition sources including compressor unit.
---	---



1.13.1. Do not smoke when spraying paint, insecticides or other flammable substances.

1.13.2. Use a face mask/respirator when spraying and spray in a well ventilated area to prevent health and fire hazards.

1.13.3. Do not direct paint or other sprayed material at the compressor. Locate the compressor as far away from the spraying area as possible to minimise overspray accumulation on the compressor.

1.13.4. When spraying or cleaning with solvents or toxic chemicals, follow the instructions provided by the chemical manufacturer.

1.14. Hose precautions.

 <p><b>WARNING</b></p>  <p><b>EXPLOSION</b></p>	<p>Keep the compressor/motor at least 6m away from explosive vapours.</p>
---	---

1.14.1. Inspect hose/s before use. Do not exceed working pressure marked on hose. Do not twist, bend, knot or abrade hose. Do not wrap hose around the compressor or motor body.

1.14.2. Keep away from hot surfaces and chemicals.



2. BOX CONTENTS - ASSEMBLY - PARTS

2.1. Contents;

- 2.1.1. Air compressor.
- 2.1.2. Operation manual.
- 2.1.3. Air filter.

2.2. Assembly;

- 2.2.1. Attach the air filter to the top right side of motor head.
- 2.2.2. Screw air filter into the motor head.

2.3. Parts;

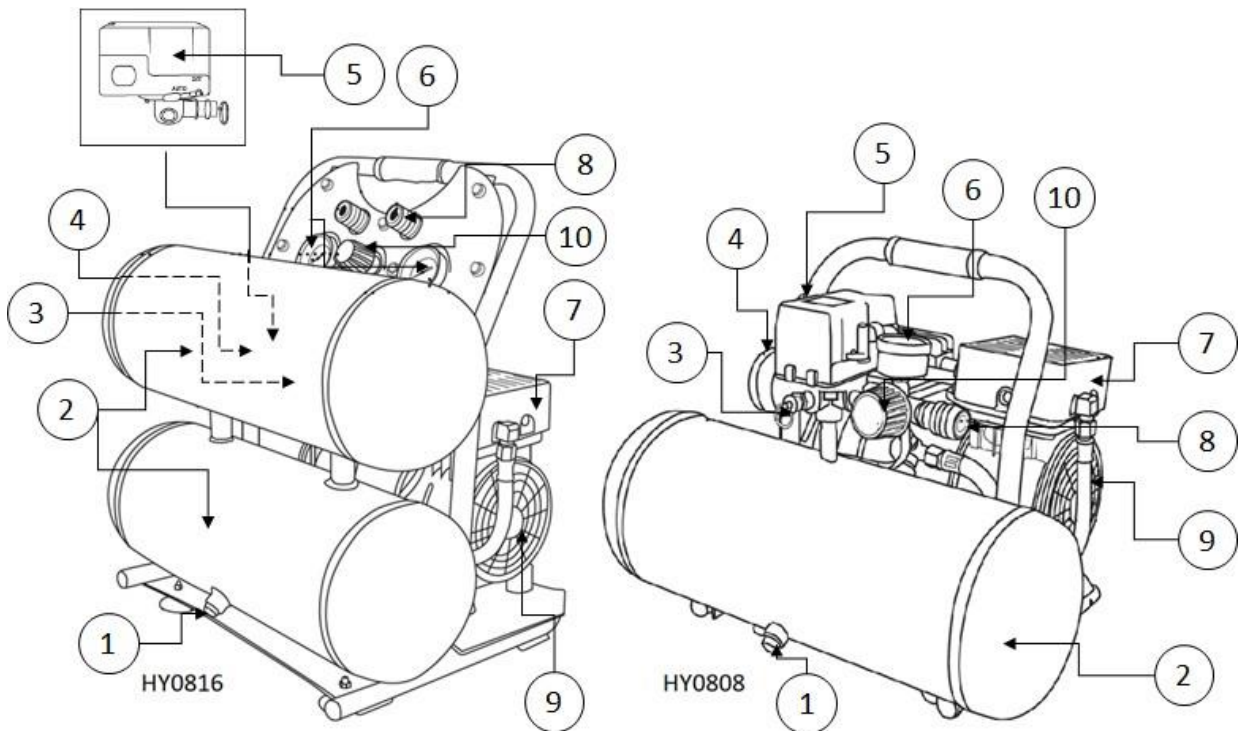



1	Tank Drain	6	Pressure Gauge/s
2	Air Tank	7	Pump Head
3	Safety Relief Valve	8	Air Coupler/s
4	Air Filter	9	Cooling Fan
5	Pressure Switch	10	Regulator

### 3. INSTALLATION & EARTHING

#### 3.1. Installation.

3.1.1. The compressor must be used on a stable and level surface. The air compressor must be used in a clean and well ventilated area. The compressor requires an unobstructed airflow and must be located a minimum of 450mm from any wall or other obstructions.

#### 3.2. Earthing instructions

 <p><b>WARNING</b></p>  <p><b>ELECTRIC SHOCK</b></p>	<p>Improper installation of the earth connection can result in a risk of electric shock.</p> <p>If repair or replacement of electrical cable is necessary do not connect the earth wire to either the live or neutral pins.</p> <p>Brown is Live – Blue is Neutral – Green/Yellow striped is Earth.</p> <p>If in doubt consult a qualified Electrician.</p>
--	---

3.2.1. This product should always be used with the earth wire connected. In the event of an electrical short circuit the earth wires reduces (but does not eliminate) the risk of electric shock.

3.2.2. This product is for use on a 230 VAC 50 Hz supply.

3.2.3. This product is supplied with a cord incorporating an earth wire it must be connected to an earthed socket. It is highly recommended that you use a socket outlet that has Residual Current Device RCD. When connected to an RCD outlet it will protect user/s against electric shock.

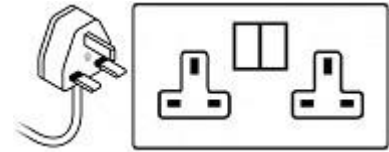

#### 3.3. Extension Leads.

3.3.1. We do not recommend the use of an electrical extension lead with this product as this may result in loss of power and overheating of the motor.

3.3.2. Additional air hoses should be considered before an electrical extension lead.

3.3.3. If the use of an extension lead is unavoidable then use only suitable extension leads which incorporate an earth connection.

3.3.4. Improper use of an extension lead can cause inefficient operation of the motor/air compressor which can result in overheating.

3.3.5. Suggested extension lead cable sizing.

<b>Extension lead length</b>	<b>Wire size</b>
Up to 7.5 m	2.5 mm <sup>2</sup>
7.6 m to 15 m	4.0 mm <sup>2</sup>
15.1 m to 30 m	6.0 mm <sup>2</sup>

## 4. MAINTENANCE

### 4.1. Draining Air Tank.

- 4.1.1. The frequency at which you should drain the air tank depends on the environmental conditions and the amount of operating time logged.
- 4.1.2. The average draining frequency is every two/three days.
- 4.1.3. Place the air compressor above a container capable of holding water.
- 4.1.4. With compressed air in air tank, slowly turn the drain valve knob anti-clockwise. The water in the air tank will drain out.
- 4.1.5. After all of the accumulated water has drained out, turn the drain valve knob clockwise until it is tight, this will avoid leakage.

### 4.2. Changing the air filter.

- 4.2.1. The air filter is designed to reduce noise and help dust particles from entering and damaging the air compressor.
- 4.2.2. After being used for a period of time, the air filter will become clogged. This will reduce the air intake capabilities of the air compressor, reducing performance, therefore the air filter must be replaced regularly.
- 4.2.3. Open the lid on the air filter, then remove old filter.
- 4.2.4. Replace it with a new filter, then close the lid.

### 4.3. Testing for leaks.

- 4.3.1. Make sure all connections are tight but be careful not to overtighten.
- 4.3.2. A small leak in any hose or pipe connection will reduce the air compressors performance.
- 4.3.3. To test for small leaks spray a small amount of soapy water on suspected area of leakage. If soap solution bubbles, tighten or replace part/s.

### 4.4. Cleaning.

- 4.4.1. Clean items with a soft brush, or wipe with a moistened cloth using a biodegradable cleaner.
- 4.4.2. Do not use flammable liquids such as petrol or alcohol. Always keep parts clean from dirt and dust for a better performance.

### 4.5. Adjusting the pressure switch.

- 4.5.1.1. The pressure switch should only be adjusted by suitably qualified persons.

5. STORAGE

5.1. Before storing for a prolonged period of time carry out the following;

- 5.1.1. Turn off the power supply.
- 5.1.2. Disconnect the power lead from the power supply.
- 5.1.3. Pull the relief valve and release all air pressure form the tank.
- 5.1.4. Drain compressor as in 4.1 above.
- 5.1.5. Clean the air compressor to remove all dirt and dust.
- 5.1.6. Cover the air compressor with a cover to protect the unit from dust and moisture, make sure compressor is cold before covering.
- 5.1.7. Do not stack or store any items on top or around the air compressor, otherwise damage may occur.

6. TROUBLESHOOTING

6.1. If you are experiencing a problem that is not listed in this chart, or have checked all possible causes listed and you are still experiencing problems please contact your dealer.

<b>Problem</b>	<b>Possible Causes</b>	<b>Remedies</b>
Pressure drops in the tank.	Air leaks at connections.	Let the air compressor build up pressure in the tank, to the maximum pressure. If possible brush soapy water on air connections and look carefully for air bubbles. Tighten leaky connections. If problem persists contact your dealer for further advice.
The solenoid valve leaks when the compressor is idle.	Non-return valve seal defective.	Let the air in the tank flow out until all pressure is released. Then remove the no-return valve plug and clean the valve seal. If necessary replace the seal and then reinstall all components.
The compressor stops and does not restart.	Overload cut-out operated because of motor overheating.	Check that the mains voltage corresponds to specification. An extension cord that is too thin or too long can cause a volt drop and cause the motor to overheat. Allow motor to cool down. Use heavy duty extension leads. Make sure the compressor is plugged into a socket as close to the supply as possible.
	Motor winding are burnt out.	Contact your dealer.
The motor does not start and makes a humming noise.	Capacitor is burned out.	Replace starter capacitor.
The motor does not start or starts slowly.	Low voltage supply to the motor.	Check that the mains voltage corresponds to specification. An extension cord that is too thin or too long can cause a volt drop and cause the motor to overheat. Allow motor to cool down. Use heavy duty extension leads. Make sure the compressor is plugged into a socket as close to the supply as possible.
The compressor is noisy with metallic clangs.	Compressor head gasket broken of faulty valve.	Stop the compressor and contact your dealer.

The compressor does not reach maximum pressure.	Compressor head gasket broken or faulty valve.	Stop the compressor and contact your dealer.
Compressor doesn't seem to provide as much air it did when new and/or the compressor cuts off within a much shorter time period.	The pressure switch needs adjusting.	Stop the compressor and contact your dealer.
	The tank is full of water due to condensation.	Open the ball valve and release the pressure. Open the drain valve and release the water within the tank.
The motor pump unit does not stop when the tank pressure reaches its maximum working pressure (8 Bar/116PSi) and the safety valve vents air	Pressure switch defective or needs adjusting.	Stop the compressor immediately and contact your dealer.

## 7. SPECIFICATIONS

Model	HY0808	HY0816
<b>Voltage - V</b>	230	230
<b>Number of phases</b>	1	1
<b>Frequency – Hz</b>	50	50
<b>Connection method/Cable length m</b>	3 pin plug - BS1363A/1.4	3 pin plug - BS1363A/1.4
<b>Motor power hp/kw</b>	0.75/0.56	0.75/0.56
<b>Rated Speed (motor) – RPM</b>	1430	1430
<b>Cubic Foot per Minute @ 6.2 Bar</b>	2.4	2.4
<b>Maximum Pressure - PSi/Bar</b>	145/10	145/10
<b>Cut-out Pressure - PSi/Bar</b>	128/8.8	128/8.8
<b>Cut-in Pressure - PSi/Bar</b>	87/6	87/6
<b>Tank Capacity - L</b>	8	2 x 8
<b>Free air delivery - CFM - L/min</b>	2.4/68	2.4/68
<b>Displacement - CFM/L/min</b>	3.1/73	3.1/73
<b>Displacement @ 40 psi L/min</b>	55	55
<b>Displacement @ 90 psi L/min</b>	32	32
<b>Air Outlet</b>	Machine - Male 3/8" tapered quick release euro/Hose - Male 3/8" euro coupling	Machine - Male 3/8" tapered quick release euro/Hose - Male 3/8" euro coupling
<b>Output pressure regulation type</b>	Adjustable	Adjustable
<b>Drive type</b>	Direct	Direct
<b>Overall Unit Dimensions L x W x H mm</b>	490 x 405 x 390	490 x 400 x 530
<b>Net Weight - kg</b>	17.3	23.2
<b>Tank material</b>	Rolled steel	Rolled steel

## 8. ENVIRONMENTAL

- 8.1. Do not dispose of electric equipment together with household waste material! In observance of European Directive 2012/19/EC on waste electrical and electronic equipment and its implementation in accordance with national law, electric equipment that have reached the end of their life must be collected separately and returned to an environmentally compatible recycling facility. If electrical appliances are disposed of in landfills or dumps hazardous substances can leak into the groundwater and get into the food chain, damaging your health and well-being.
- 8.2. For further information on the disposal of this product, please contact your dealer or your nearest domestic waste collection service.

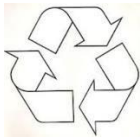

- 8.3. Reduce – Reuse - Recycle unwanted materials instead of disposing of them as waste. All tools, accessories and packaging should be sorted, taken to a recycling centre and disposed of in a manner which is compatible with the environment.



- 8.4. When the product is no longer required, it must be disposed of in a manner which is compatible with the environment.

## 9. GENPOWER CONTACT DETAILS

### 9.1. Postal address;

Genpower Limited, Isaac Way, Pembroke Dock,  
Pembrokeshire, SA72 4RW, UK.

### 9.2. Telephone and Fax contact numbers;

Office                    +44 (0) 1646 687880

### 9.3. Email contact;

Technical                [service@genpower.co.uk](mailto:service@genpower.co.uk)

### 9.4. Web site;

[www.hyundaipowerequipment.co.uk](http://www.hyundaipowerequipment.co.uk)

## 10. DECLARATIONS OF CONFORMITY

10.1. Genpower Ltd confirms that this Hyundai product conform to the following CE Directives;

10.1.1. 2002/95/EC Restriction of Hazardous Substances

10.1.2. 2004/108/EC EMC Directive

10.1.3. 2006/42/EC Machinery Directive

10.1.4. 2006/95/EC Low Voltage Directive

10.1.5. 87/404/EC Simple Pressure Directive

**HYUNDAI**

**GENPOWER LTD**

Isaac Way, London Road  
Pembroke Dock, UNITED KINGDOM, SA72 4RW  
T: +44 (0) 1646 687 880 F: +44 (0) 1646 686 198

E: [info@hyundaipowerequipment.co.uk](mailto:info@hyundaipowerequipment.co.uk)

---

[www.hyundaipowerequipment.co.uk](http://www.hyundaipowerequipment.co.uk)