

UCA

High-Speed Passenger Elevator Planning Guide

The information in this catalogue is subject to change without notice. The information and diagram in this catalogue reflect the technical feature and configuration of the elevator model at press time (refer to the version number). In line with the principle of continuous development of products, our company reserves the right to change the selection of product technical parameters and colour at any time. The existing image technology cannot accurately reproduce the elevator component structure and decoration colour. Therefore, this catalogue only provides general information, not as a contract document. The specific configuration parameters are subject to the formal agreement.

If you need detailed information, please contact us.

02 Specification

03 Layout

04 FI System

07 Elevator Function

09 Overhead Height and Pit Depth

10 Hoistway and Machine Room

15 Entrance Design

17 Electrical Information

18 Electrical Data

19 Civil Works Matters

Load (kg)	No. of Passengers ①	Speed (m/min)	Maximum Number of Stops	Maximum Travel (m)	Maximum Travel with Fireman Operation (m)	Minimum Floor Height (mm)
900	12	300/360	64 (Duplex / Group Control) 80 (Simplex Control)	250	250	2800
1050	14	300/360		250	250	
1150	15	300/360		250	250	
1350	18	300/360		250	250	
1600	21	300/360		220	220	
1800	24	300/360		200	200	
2000	26	300/360		250	250	
2250	30	300/360		200	200	

Load (kg)	No. of Passengers ①	Speed (m/min)	Maximum Number of Stops	Maximum Travel (m)	Maximum Travel with Fireman Operation (m)	Minimum Floor Height (mm)
1150	15	420/480	64 (Duplex / Group Control) 80 (Simplex Control)	285	285	2800
1350	18	420/480		285	285	
1600	21	420/480		285	285	
1800	24	420/480		285	285	

Note:

① Passenger numbers calculated at 75kg per person.

② The information above are based on GB standards.

③ The maximum travel for the load of 1150/1350/1600kg with speed of 300/360 m/min could be up to 330m with conditions. Details, please contact us.

④ The maximum travel for the load of 1800kg with speed of 300/360 m/min could be up to 300m with conditions. Details, please contact us.

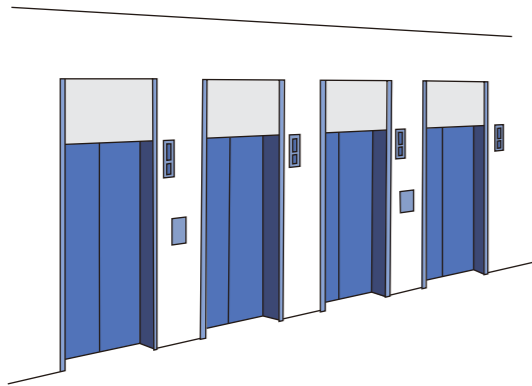

- Maximum in-line arrangement is 4 elevators.
- Elevators in different groups should not be set in the same line.
- Avoid placing the elevators entrance near pillars.

- More than 5 units in the same group, the elevators should be set face-to-face. And the distance of facing elevators(L) should be 3.5~4.5m.
- Different group elevators with face-to-face arrangement, the distance of facing elevators(L) should be more than 6m.

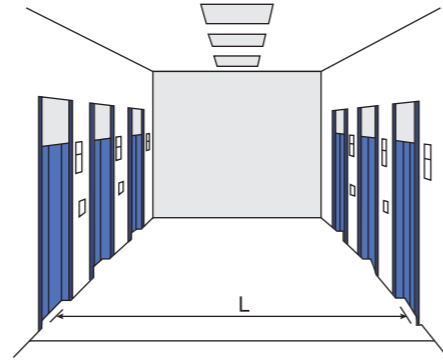

- Elevators in same group should have same stops.
- Elevators in same group should be set the same floor as basement and not recommend to set several entrance.

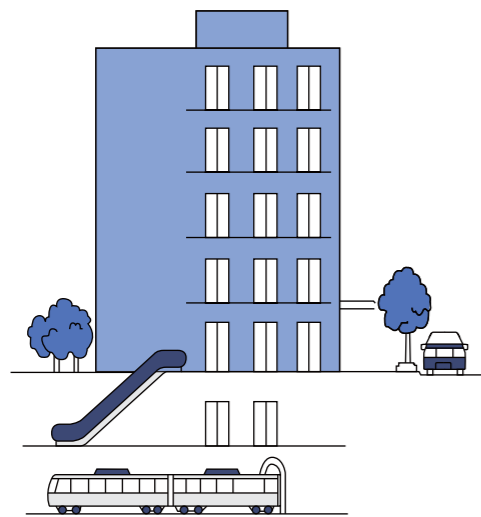

<FI-600 Features> Future Reference-Trajectory Control

A group control system groups multiple elevators for achieving a well-balanced operation by taking waiting times into account. Such a system requires flexibility so that it can be used in various types and sizes of buildings and be responsive to changing traffic demand.

(FI-600) (3-8 Cars)	(FI-100) (3-6 Cars)	(FI-10) (3-4 Cars)
Allows a flexible control for elevator car allocation and the required number of cars according to the congestion state in the building and the type of building.	Elevator cars are allocated at equal time intervals according to "Reference-Trajectory Control" for shortening the average waiting times and reducing the probability of a long wait.	Provides a ring control to allocate the elevator car closest to the floor where a new hall call is registered.

Basic Specification	Instantaneous reservation and service forecasting		
	Intelligent function		
	Generation of new traffic flow modes Generation of optimum operation programs		
	Congested floor recognition		
	Learning function		
	<ul style="list-style-type: none"> • Collection of usage data • Recognition of traffic flow mode (40/2 modes) • Search for optimum operation program 		
	Arrival notice indication (hall lantern and chimes)		
Bunching prevention ①			
	Future reference-trajectory control	Reference-trajectory control	Ring control
	Forecasting dynamic allocation control	Zone distribution control	Fixed floor distribution control
System name	FI-600	FI-100	FI-10
Recommended number of cars in a group	3~8 cars	3~6 cars	3~4 cars
Type of building	Large office buildings and hotels	Small office building, department stores, hotels and hospitals	Building with small traffic demand
Optional	VIP service, independent automatic operation		
	Service floor selection		
	Destination floor reservation system Centralized control for special floors Zoning express service		

Note:

① Bunching prevention: Using the "future reference-trajectory control" or the "reference-trajectory control" in the FI-600 or FI-100, elevator cars are operated at equal time intervals to prevent local bunching.

Basic Function

● : Basic spec. ▲ : Option spec. — : Not applicable

No.	Item	Content	FI-600	FI-100	FI-10
1	Instantaneous reservation and service forecasting (FI-HRF)	Upon receipt of a hall call, this function activates and elevator to serve this call, and at the same time the call is acknowledged by the hall lantern and chime.	●	—	—
2	Arrival notice indication (FI-ANI)	Four to five seconds prior to the arrival of an elevator, this function will activate the hall lantern flickering and the chime sound.	●	●	▲
3	Basic call assignment control	Future reference-trajectory control (FI-FRTC)	●	—	—
		Reference-trajectory control (FI-RTC)	—	●	—
4	Personalized control	Through the hall call assignment control of waiting time priority assignment, constantly carry out operation management in accordance with waiting time priority.	●	●	—
	Waiting time priority assignment	Prevent long waiting time of passengers by implementation of hall call assignment.	●	●	—
	Riding time priority assignment	Prevent long riding time of passengers by implementation of hall call assignment.	▲	▲	—
	Bunching prevention (FI-BP)	This function prevents local bunching of elevator cars using the "future reference-trajectory control" or the "reference-trajectory control" for operating cars at equal time intervals.	●	●	—
5	Learning function	Collection of usage data (FI-CUD)	●	●	—
		Recognition of traffic flow mode (FI-RTM)	● (40 modes)	● (2 modes)	—
		Search for optimum operation program (FI-SOP)	●	●	—
6	Congested floor recognition (FI-CFR)	Identifies congested floors according to the usage data learned in each traffic flow mode.	●	—	—
7	Service forecasting for hall call assignment (FI-SFH)	This function assigns elevator cars to hall calls more precisely by forecasting the arrival time and number of passengers in the car according to the learning-based traffic demand.	●	—	—
8	Intelligent function	Generation of new traffic flow modes (FI-GNT)	●	—	—
		Generation of optimum operation programs (FI-GOP)	●	—	—
9	Energy saving preference control (FI-ESC)	This system reduces the number of elevator cars in service when traffic demand is low.	●	—	—
10	Floor standby control	Forecasting dynamic allocation control (FI-FDA)	●	—	—
		Zone distribution control (FI-ZD)	—	●	—
		Fixed floor distribution (FI-FD)	—	—	●

Basic Function

● : Basic spec. ▲ : Option spec. — : Not applicable

No.	Item	Content	FI-600	FI-100	FI-10
11	Learning based concentrated service (FL-LCS)	Centralizes the service to the learning-based congested floors during peak times including morning, lunch time and evening peaks while taking the service for other floors into account.	●	—	—
12	Rush-hour schedule operation	All the elevators will automatically return to the start floor after serving the last call during this preset rush-hour timing.	●	—	▲
13	Destination floor priority control	The allocation will be priority when the destination floor and the hall call is the same floor.	●	●	—
14	Full car forecasting control	Control the new allocation according to the number of passengers in car and the times of new calls.	●	●	—
15	Full car control	Stop new allocation or re-allocate the car when full load.	●	●	—
16	Long waiting time allocation control	Re-allocate the cars when long waiting time situation is forecasted.	●	●	—
17	Notice function	Keep the service elevator car door open with hall lantern flickering to guide the passengers.	▲	●	—
18	Automatic door open time control (FI-ADT)	This function automatically controls the duration of the door open time according to the floor and the kind of call (hall call or car call) as well as the elevator condition.	●	●	—

Operating Function

No.	Item	Content	FI-600	FI-100	FI-10
1	Centralized control for special floors (FI-CCF)	This function preferentially assigns an elevator to the special floor. (e.g. the director's room)	▲	—	—
2	Service floor selection (FI-SFS) [Floor lock-out operation]	Allows the operator to select the service and non-service floors using, for example, the switches on the control panel.	▲	▲	—
3	VIP service (FI-VIP)	When welcoming or sending off important guest, this function permits an elevator to be summoned directly to the desired car call floor by pushing a specially provided switch.	▲	▲	▲
4	DFRS	Each passenger registers their destination floor on the registration device located at the landing hall and know in advance the designated elevator to take. System assigned one elevator for the passengers with the same destination floor. This helps to reduce congestion in the elevator lobby and improve efficiency.	▲	—	—
5	Zoning express service (FI-EZS)	Start a divided express service when the peak traffic demand takes place in the present time zones.	▲	—	—

Man-machine Function

No.	Item	Content	FI-600	FI-100	FI-10
1	Malicious operation cancelled function	Cancel the allocation when system identifies the call is malicious.	●	●	—
2	Hall information (FI-HI)	General and elevator operation information is indicated on the LED or LCD hall indicator.	—	—	●

Elevator Function

Standard Function

Control System			
SA1	Simplex Collective Control	SA2	Floor Height Self Measurement
SA3	On-Cage (Car Top) Maintenance Operation	SA4	In-Cage Slow Speed Operation
SA5	Machine-Room Debugging Operation Function		
System Protection			
SB1	Over Speed Electrical Protection	SB2	Overspeed Mechanical Protection
SB3	Rope Slipping Running Protection	SB4	Motor Overload (Thermal) Protection
SB5	Automatic Fault Detection	SB6	Automatic Fault Recording
SB7	Standby Regular Auto-Check	SB8	Double Brake-Safety Check Operation
SB9	Synchronous Motor Magnetic Pole Static Test	SB10	Lift-Position Abnormally Auto-Correction Function
SB11	Nearest Landing Operation	SB12	Anti-electromagnetic Interference
Safe Communication			
SC1	Interphone System (5 Ways)		
Safe Riding			
SD1	Out of Door-Open Zone Alarm	SD2	Alarm System
SD3	Door Safety Return System	SD4	Full Load Bypass Operation
SD5	Overload Detection System	SD6	Overload Alarm
SD7	Next Drive (Door Open Abnormity)	SD8	Door Opening / Closing Time Abnormity Protection
SD9	Automatic Door Dwell Time Control	SD10	Automatic Door Dwell Time Adjustment
SD11	Number of Runs Indicator	SD12	Multi-Beam Protection ①
SD13	Inspection Indication in Hall Indicator	SD14	Current Floor Push-Button Reopening Function ①
SD15	Overload Indicator (In Car)	SD16	Emergency Terminal Stopping Device, ETSD
Emergency Solution			
SE1	Car Emergency Lighting	SE2	Fire Emergency Operation (Automatic)
Design for Comfort			
SF1	Parking Operation	SF2	Automatic Return Function
SF3	Start Torque Auto-Adjustment	SF4	Door-Stop Function (Maintenance)
SF5	Micro Levelling (Travel ≥45m)	SF6	Advance Door Opening
SF7	Mischievous Call Cancellation	SF8	Opposite Direction Car Call Cancellation
SF9	Car Light Auto Turn-off	SF10	Car Fan Auto Turn-off
SF11	Abnormal Duration Hall Call Detection ① (Applicable for Simplex, Duplex and FI-10 only.)	SF12	Car Floor Button Flashing ①
SF13	Car Call Deselect Function	SF14	Regenerative System Function
SF15	Door Bypass Detection	SF16	Overload Hall Call Recovery Function (Not applicable for FI-100 and FI-600.)
SF17	Base Floor Selection (Applicable for Simplex only.)		

Note:
① Details, please contact us.

Elevator Function

Optional Function

Control System			
OA1	Simplex Down Collective Control	OA2	Duplex Collective Control
OA3	Duplex Down Collective Control	OA4	FI-10 ①
OA5	FI-100 ①	OA6	FI-600 ①
OA7	Independent Automatic Operation ①	OA8	VIP Service
OA9	Rush Hour Schedule Operation (Not applicable for FI-100)		
Safe Communication			
OB1	Contact at Control Panel (RS485)	OB2	Elevator Monitoring System (Computer Type)
OB3	Supervisory Panel (Dry Contact Type)	OB4	Twisted Pair Cable (1 pair) for CCTV
OB5	Twisted Pair Cable (1 pair) for BGM Interface	OB6	Contact at Control Panel (Dry Contact)
OB7	Camera Device in Inside the Car		
Safe Riding			
OC1	Multi-Beam + Safety Edge Protection	OC2	Card Reader Interface (In Car) (RS485) ① (Not applicable when OE5 is selected.)
Emergency Solution			
OD1	Fireman Operation (Load>825kg)	OD2	Automatic Rescue Device (ARD) (Maximum travel distance ≤ 30m)
OD3	EM. Operation for Power Failure (Manual)	OD4	EM. Operation for Power Failure (Auto)
OD5	Earthquake Emergency Operation	OD6	Pit Flood Operation
Design for Comfort			
OE1	Attendant Operation	OE2	Independent Operation
OE3	Voice Synthesizer	OE4	Arrival Chime (Car Top and Bottom)
OE5	Floor Lock Out Operation ① (Not applicable when OC2 is selected.)	OE6	Door Opening Prolong Button
OE7	Hall Call Registration in Car Operating Panel (Applicable when OE1 is selected)	OE8	Sub Car Operating Panel
OE9	Double Opening Function ① (Not applicable for FI-100, FI-600 and FI-10 (>48 stops.))	OE10	Horizontal Car Operating Panel
OE11	Braille Button	OE12	EMC ①
OE13	Operation Status Indication at Hall Indicator	OE14	DFRS (Under FI-600)
OE15	Hall Call Deselect Function ① (Applicable for Simplex, Duplex and FI-10 only.)		

Note:
① Details, please contact us.

Overhead Height and Pit Depth

Hoistway and Machine Room (Standard Car Design, Counterweight Location: Rear)

Load (kg)	Speed (m/min)	Overhead Height OH (mm)		Pit Depth P (mm)	
		Double	Single	Double	Single
900	300	7100	6900	3750	4100
	360	7400	7100	4100	4400
1050	300	7100	6900	3750	4100
	360	7400	7100	4100	4400
1150	300	7100	6900	3750	4100
	360	7400	7100	4100	4400
	480	8100	—	5850	—
1350	300	7100	6900	3750	4100
	360	7400	7100	4100	4400
	480	8100	—	5850	—
1600	300	7100	6900	3750	4100
	360	7400	7100	4100	4400
	480	8100	—	5850	—
1800	300	7100	6900	3750	4100
	360	7400	7100	4100	4400
	480	8100	—	5850	—
2000	300	7100	6900	3750	4100
	360	7400	7100	4100	4400
2250	300	7100	6900	3750	4100
	360	7400	7100	4100	4400

- Note:
- The information and dimensions above are based on GB standards.
 - Configuration is based on rear counterweight arrangement without counterweight safety gear.
 - The information above is based on decoration weight provision up to 450kg.
 - The overhead height above is based on bare ceiling height of 2800mm.
 - The pit depth above is based on standard vinyl tile finish without floor recess.

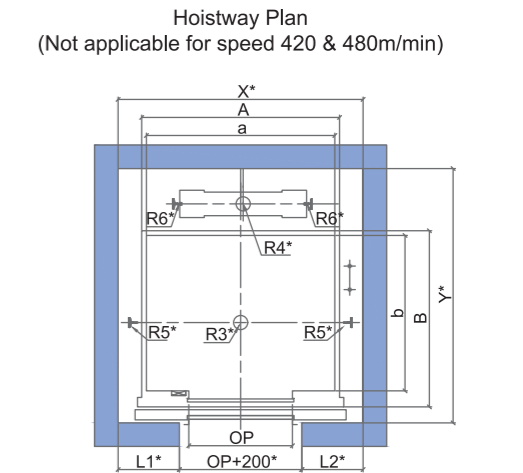
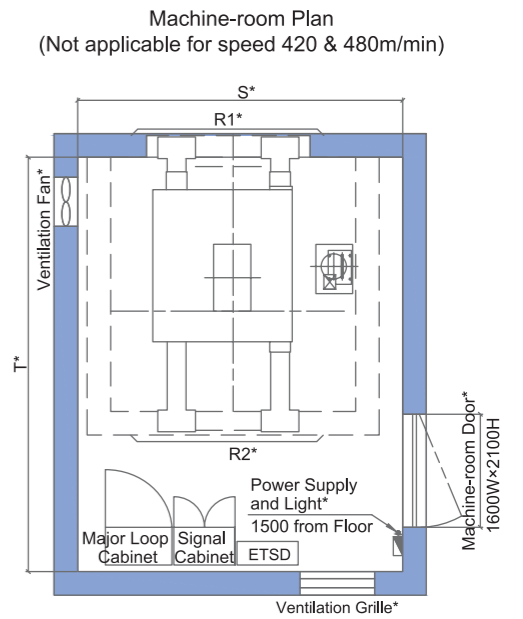
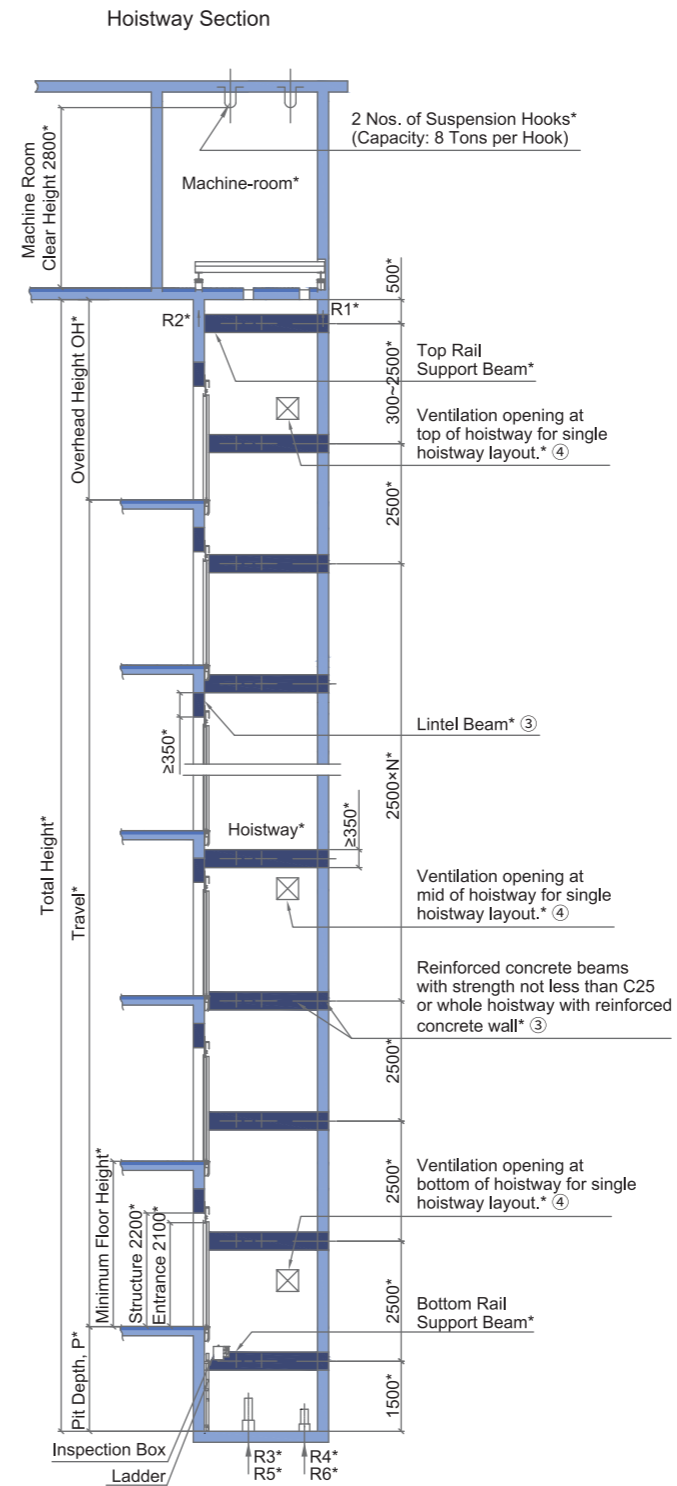

- Note:
- Items with "*" shall be furnished by building contractors.
 - Hoistway shall not be located next to bedrooms, classroom, ward, library or any other places where low noise is required.
 - The hoistway construction shall be reinforced concrete ring beam with strength C25 or whole hoistway of reinforced concrete wall. If you have other situations, please contact us.
 - For hoistway and machine room details, please contact us.
 - Unit of dimension shall be in mm unless otherwise stated.

Hoistway and Machine Room

(Standard Car Design, Counterweight Location: Rear)

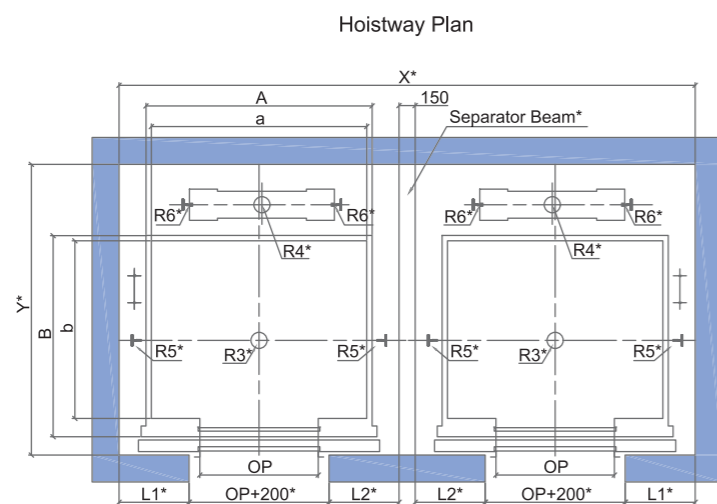
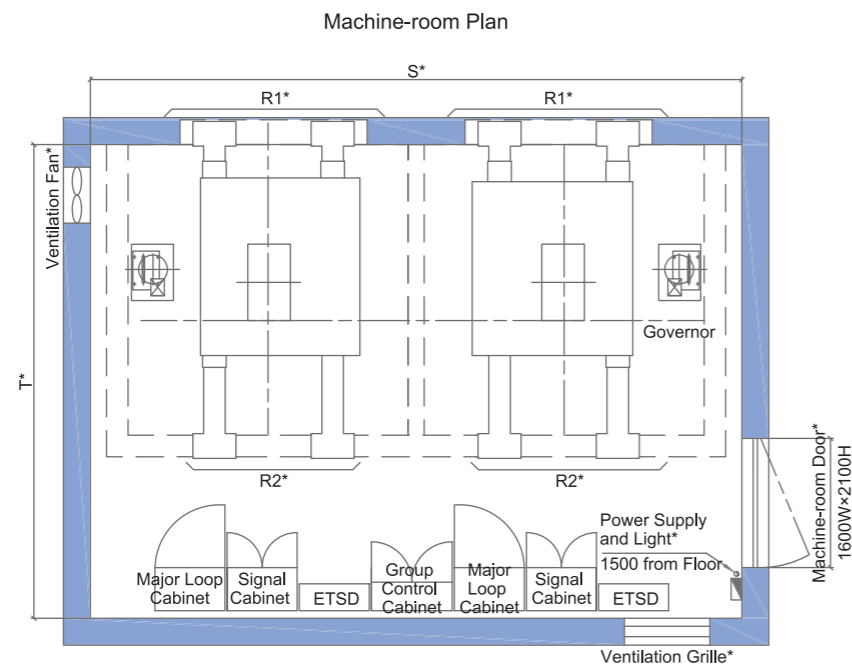

- Note:
- ① Items with "*" shall be furnished by building contractors.
 - ② Hoistway shall not be located next to bedrooms, classroom, ward, library or any other places where low noise is required.
 - ③ The hoistway construction shall be reinforced concrete ring beam with strength C25 or whole hoistway of reinforced concrete wall. If you have other situations, please contact us.
 - ④ For hoistway and machine room details, please contact us.
 - ⑤ Unit of dimension shall be in mm unless otherwise stated.

Hoistway and Machine Room

(Standard Car Design, Counterweight Location: Rear)

Single

Load (kg)	Speed (m/min)	Car Size (mm)		Door Opening (mm)		Front Wall Arrangement (mm)		Hoistway (mm)	Machine Room (mm)	Reaction Loading (KN)					
		Internal (a×b)	External (A×B)	Type	Width (OP)	L1	L2			Machine Room		Pit			
								X×Y	S×T	R1	R2	R3	R4	R5	R6
900	300	1600×1350	1700×1570	2P-CO	900	570	570	2240×2350	2570×4050	265	165	520	520	160	160
	360									265	165	580	580	160	160
1050	300	1600×1500	1700×1720	2P-CO	900	570	570	2240×2500	2570×4200	265	165	520	520	160	160
	360									265	165	580	580	160	160
1150	300	1800×1500	1900×1720	2P-CO	1000	620	620	2440×2500	2670×4200	290	195	550	550	180	180
	360									290	195	600	600	180	180
1350	300	2000×1500	2100×1720	2P-CO	1100	670	670	2640×2500	2770×4200	310	200	560	560	185	185
	360									310	200	610	610	185	185
1600	300	2000×1700	2100×1920	2P-CO	1100	670	670	2640×2700	2770×4400	310	215	580	580	190	190
	360									310	215	630	630	190	190
1800	300	2200×1700	2300×1920	2P-CO	1200	720	720	2840×2700	2940×4400	325	230	600	600	195	195
	360									325	230	650	650	195	195
2000	300	2200×1850	2300×2070	2P-CO	1200	720	720	2840×2850	2940×4550	325	230	610	610	195	195
	360									325	230	670	670	195	195
2250	300	2200×2000	2300×2220	2P-CO	1200	720	720	2840×3000	2940×4700	325	230	610	610	195	195
	360									325	230	670	670	195	195

Double

Load (kg)	Speed (m/min)	Car Size (mm)		Door Opening (mm)		Front Wall Arrangement (mm)		Hoistway (mm)	Machine Room (mm)	Reaction Loading (KN)					
		Internal (a×b)	External (A×B)	Type	Width (OP)	L1	L2			Machine Room		Pit			
								X×Y	S×T	R1	R2	R3	R4	R5	R6
1150	300	1800×1500	1900×1720	2P-CO	1000	600	600	4950×2480	5050×4180	290	195	550	550	180	180
	360									290	195	600	600	180	180
1350	300	2000×1500	2100×1720	2P-CO	1100	650	650	5350×2480	5450×4180	310	200	560	560	185	185
	360									310	200	610	610	185	185
1600	300	2000×1700	2100×1920	2P-CO	1100	650	650	5350×2680	5450×4380	310	215	580	580	190	190
	360									310	215	630	630	190	190
1800	300	2200×1700	2300×1920	2P-CO	1200	700	700	5750×2680	5850×4380	325	230	600	600	195	195
	360									325	230	650	650	195	195
2000	300	2200×1850	2300×2070	2P-CO	1200	700	700	5750×2830	5850×4530	325	230	610	610	195	195
	360									325	230	670	670	195	195
2250	300	2200×2000	2300×2220	2P-CO	1200	700	700	5750×2980	5850×4680	325	230	610	610	195	195
	360									325	230	670	670	195	195

- Note:
- ① The information and dimensions above are based on GB standards.
 - ② Hoistway dimension for double elevators are based on 150mm width separator beam.
 - ③ Configuration is without counterweight safety gear.

Hoistway and Machine Room

(Standard Car Design, Counterweight Location: Rear)

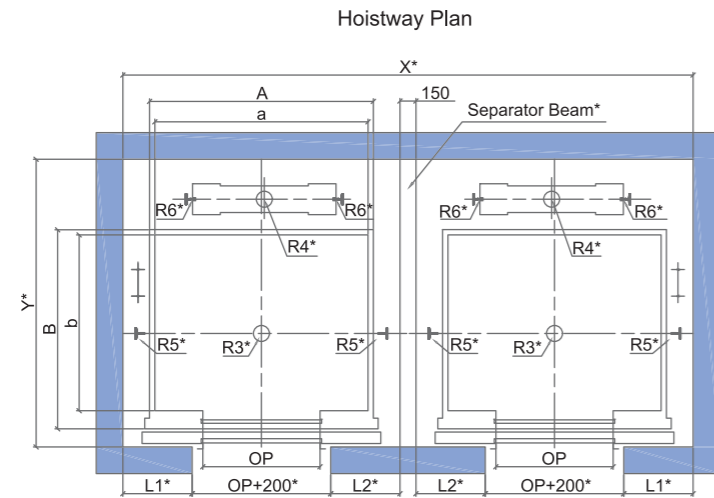
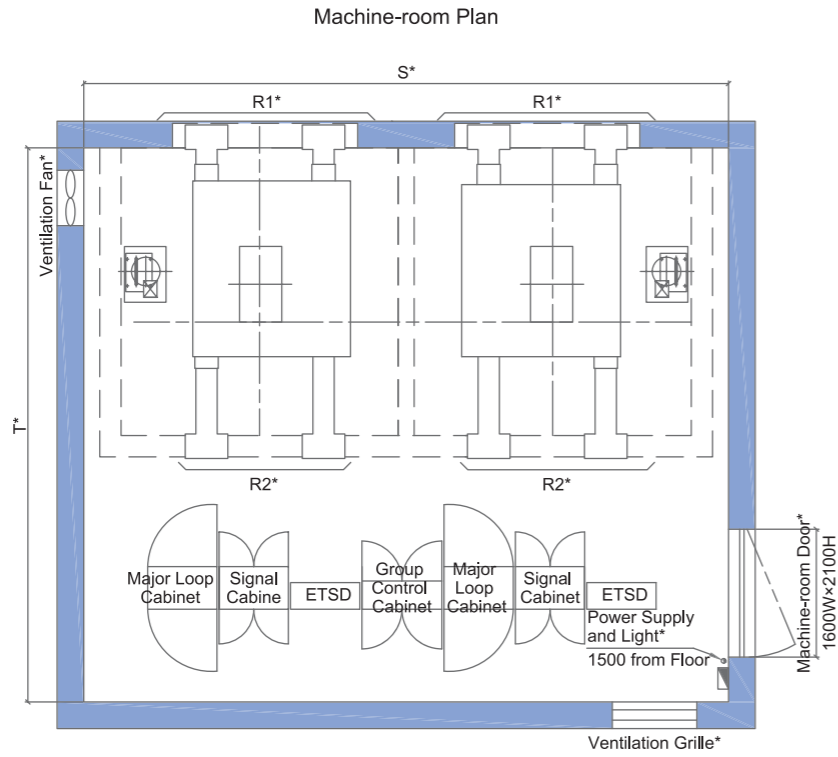

- Note:
- ① Items with "*" shall be furnished by building contractors.
 - ② Hoistway shall not be located next to bedrooms, classroom, ward, library or any other places where low noise is required.
 - ③ The hoistway construction shall be reinforced concrete ring beam with strength C25 or whole hoistway of reinforced concrete wall. If you have other situations, please contact us.
 - ④ For hoistway and machine room details, please contact us.
 - ⑤ Unit of dimension shall be in mm unless otherwise stated.

Hoistway and Machine Room

(Standard Car Design, Counterweight Location: Rear)

Double

Load (kg)	Speed (m/min)	Car Size (mm)		Door Opening (mm)		Front Wall Arrangement (mm)		Hoistway (mm)	Machine Room (mm)	Reaction Loading (KN)					
		Internal (a×b)	External (A×B)	Type	Width (OP)	L1	L2			Machine Room		Pit			
								X×Y		S×T		R1	R2	R3	R4
1150	420	1800×1500	1900×1720	2P-CO	1000	600	600	4950×2480	5050×4910	290	195	600	600	185	185
	480									290	195	720	720	185	185
1350	420	2000×1500	2100×1720	2P-CO	1100	650	650	5350×2480	5450×4910	310	200	610	610	190	190
	480									310	200	730	730	190	190
1600	420	2000×1700	2100×1920	2P-CO	1100	650	650	5350×2680	5450×5110	320	215	640	640	195	195
	480									320	215	780	780	195	195
1800	420	2200×1700	2300×1920	2P-CO	1200	700	700	5750×2680	5850×5110	325	230	660	660	200	200
	480									325	230	800	800	200	200

- Note:
- ① The information and dimensions above are based on GB standards.
 - ② Hoistway dimension for double elevators are based on 150mm width separator beam.
 - ③ Configuration is without counterweight safety gear.

Elevation of Entrance

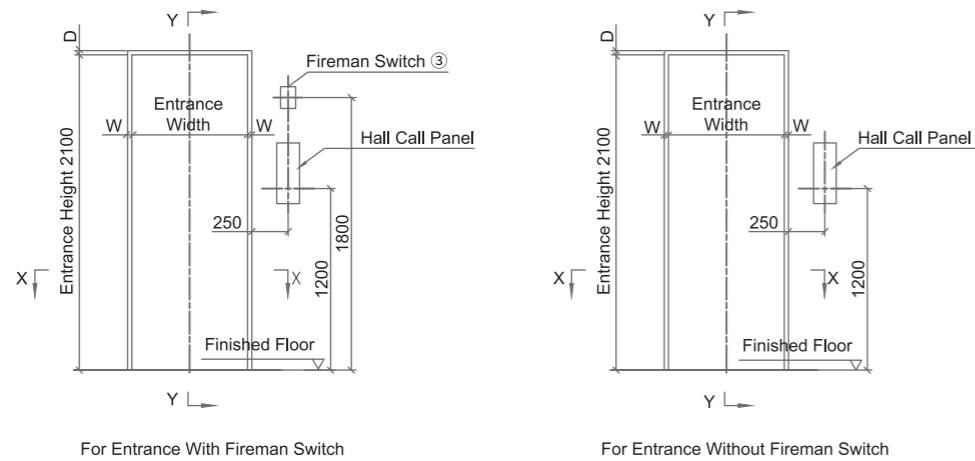

Structure Opening of Entrance ①

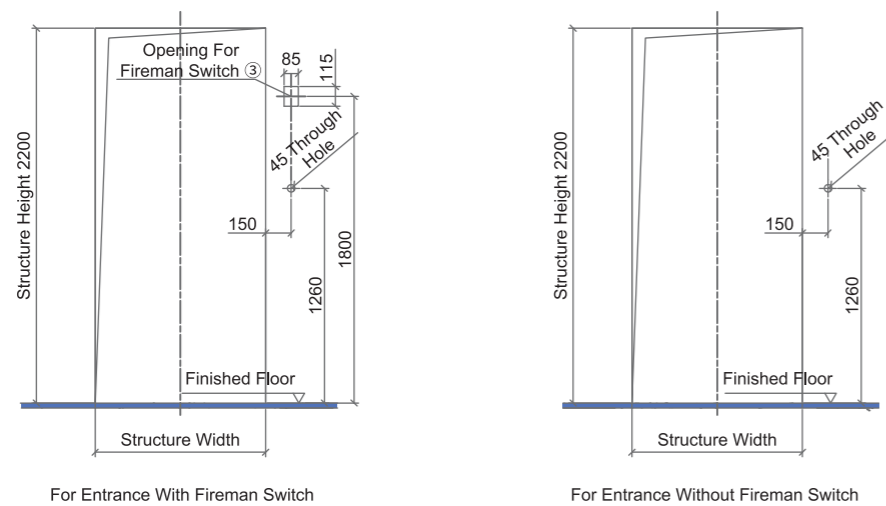

Type	AS-1X	SS-1X
W	10	25
D	10	25

- Note:
- ① Structural opening of entrance shall be furnished by building contractor.
 - ② Unit of dimension shall be in mm unless otherwise stated.
 - ③ Applicable only when fireman operation function with fireman switch is located at lift landing.

The followings shall be furnished by building contractors:

- Building Structure
- Wall and Floor Finishes
- Grouting Work

Narrow Jamb (AS-1X)

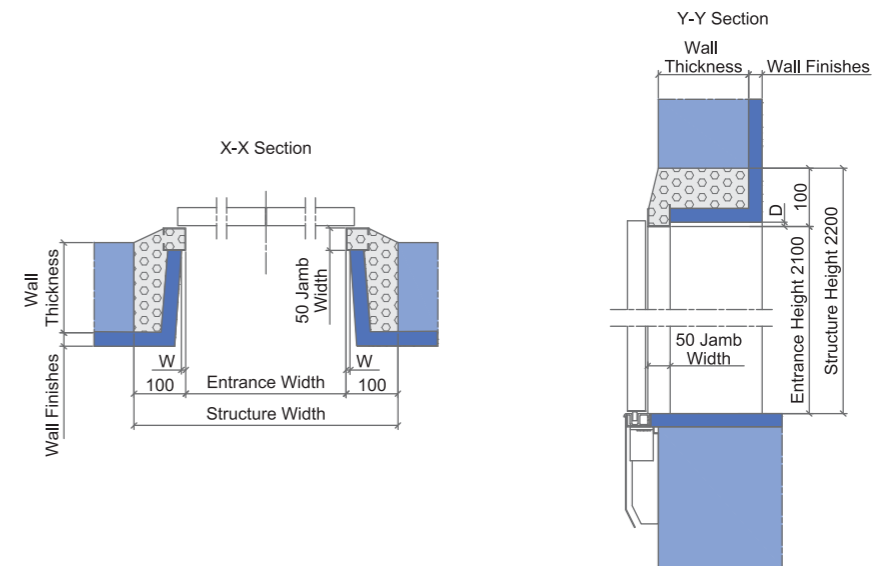

Wide Jamb (SS-1X)

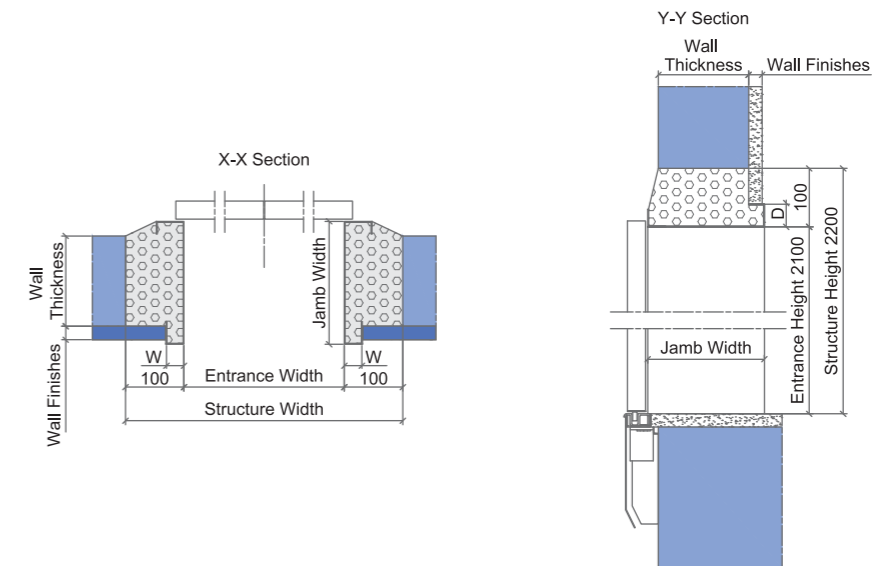

Electrical Information

The followings shall be furnished by building contractors:

~~~~~ Electrical Equipment

— Cable

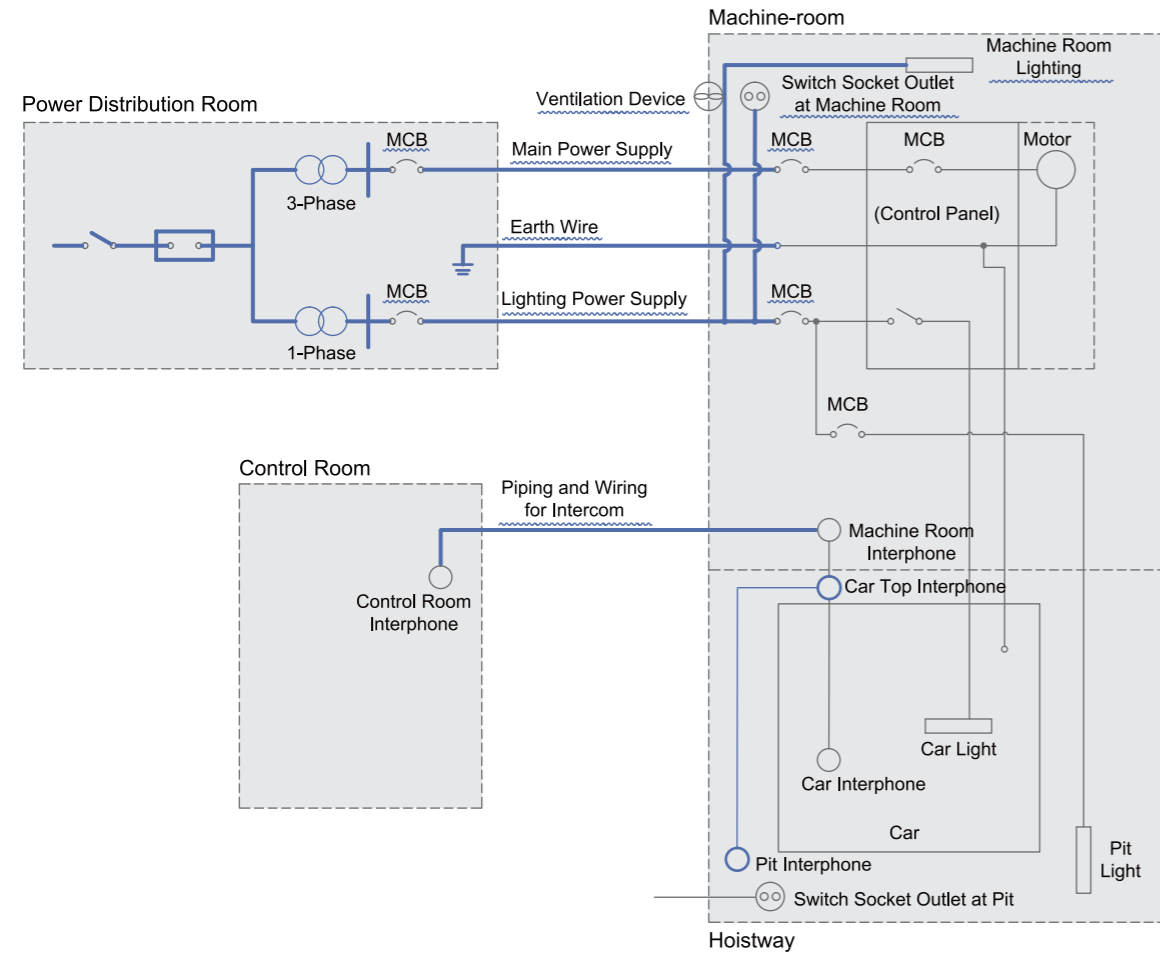

Note:  
 ① Main Power Supply: Three-phase, five wires system, AC380V 50Hz  
 ② Lighting Power Supply: Single-phase, three wires system, AC220V 50Hz

| Item                            | Works to be provided by building contractor                                                                                                                    |
|---------------------------------|----------------------------------------------------------------------------------------------------------------------------------------------------------------|
| Main Power Supply               | To provide power supply switch around the entrance of machine room. To install facilities to ensure that power supply voltage fluctuation shall be within ±7%. |
| Lighting Power Supply           | To provide lighting power supply for car lighting, fan and indicator.                                                                                          |
| Ventilation Device              | To provide mechanical ventilation to the machine room to ensure that the temperature in the machine room is maintained at below 40°C.                          |
| Pit light, Switch Socket Outlet | To provide single phase AC 220V, 10A switch socket outlet and pit lighting with switch below the entrance floor level for maintenance purposes.                |

# Electrical Data

| No. | Load (kg) | Speed (m/min) | Voltage                  | Circuit Breaker Capacity (A) |         | Transformer Capacity (kVA) |         | Main Power Wire Size (mm <sup>2</sup> ) |         | Earth Wire Size (mm <sup>2</sup> ) |         | Machine Room Ventilation        |
|-----|-----------|---------------|--------------------------|------------------------------|---------|----------------------------|---------|-----------------------------------------|---------|------------------------------------|---------|---------------------------------|
|     |           |               |                          | 1 unit                       | 2 units | 1 unit                     | 2 units | 1 unit                                  | 2 units | 1 unit                             | 2 units | Ventilation Fan Size Dia (Ø mm) |
| 1   | 900       | 300           | 3Φ380V<br>1Φ220V<br>50Hz | 200                          | 200     | 40                         | 80      | 60                                      | 125     | 30                                 | 65      | 400                             |
|     |           | 360           |                          | 200                          | 200     | 50                         | 100     | 80                                      | 150     | 40                                 | 75      | 350×2                           |
| 2   | 1050      | 300           |                          | 200                          | 200     | 50                         | 80      | 60                                      | 125     | 30                                 | 65      | 350×2                           |
|     |           | 360           |                          | 200                          | 200     | 63                         | 100     | 80                                      | 200     | 40                                 | 100     | 350×2                           |
| 3   | 1150      | 300           |                          | 200                          | 200     | 50                         | 100     | 60                                      | 125     | 30                                 | 65      | 350×2                           |
|     |           | 360           |                          | 200                          | 200     | 63                         | 125     | 80                                      | 200     | 40                                 | 100     | 400×2                           |
|     |           | 420           |                          | 250                          | 250     | 63                         | 125     | 100                                     | 280     | 50                                 | 140     | 400×2                           |
| 4   | 1350      | 300           |                          | 200                          | 200     | 63                         | 100     | 80                                      | 150     | 40                                 | 75      | 350×2                           |
|     |           | 360           |                          | 200                          | 200     | 80                         | 125     | 80                                      | 200     | 40                                 | 100     | 400×2                           |
|     |           | 420           |                          | 250                          | 250     | 80                         | 125     | 100                                     | 280     | 50                                 | 140     | 400×2                           |
|     |           | 480           |                          | 250                          | 250     | 80                         | 160     | 125                                     | 325     | 65                                 | 165     | 400×3                           |
| 5   | 1600      | 300           |                          | 200                          | 200     | 63                         | 125     | 80                                      | 150     | 40                                 | 75      | 400×2                           |
|     |           | 360           |                          | 200                          | 250     | 80                         | 160     | 80                                      | 200     | 40                                 | 100     | 400×2                           |
|     |           | 420           |                          | 250                          | 250     | 80                         | 160     | 125                                     | 325     | 65                                 | 165     | 400×3                           |
| 6   | 1800      | 300           |                          | 200                          | 250     | 80                         | 160     | 100                                     | 200     | 50                                 | 100     | 400×2                           |
|     |           | 360           |                          | 200                          | 250     | 100                        | 160     | 125                                     | 325     | 65                                 | 165     | 400×3                           |
|     |           | 420           | 250                      | 275                          | 100     | 200                        | 125     | 325                                     | 65      | 165                                | 400×3   |                                 |
| 7   | 2000      | 300           | 200                      | 250                          | 100     | 200                        | 150     | 350                                     | 75      | 175                                | 400×3   |                                 |
|     |           | 360           | 200                      | 250                          | 100     | 200                        | 125     | 325                                     | 65      | 165                                | 400×3   |                                 |
| 8   | 2250      | 300           | 200                      | 250                          | 80      | 160                        | 100     | 200                                     | 50      | 100                                | 400×2   |                                 |
|     |           | 360           | 225                      | 275                          | 100     | 160                        | 100     | 200                                     | 50      | 100                                | 400×3   |                                 |

Note:  
 ① The main power wire size specified above is applicable for wire length less than 150m.  
 For main power wire length more than 150m, please calculate using the following formula:  
 Main power wire size(mm<sup>2</sup>) = [Actual wire length / 150] × [Wire size in above table]  
 ② Ventilation rate of fan shall be as below:

| Fan Size (Φmm) | Ventilation Rate (m <sup>3</sup> /h) |
|----------------|--------------------------------------|
| 350            | 2460                                 |
| 400            | 3720                                 |



